

Xeris E

Schell Xeris E Basin Tap E-K Infrared Premixed Water (Battery Operated)

Code:
S0129406

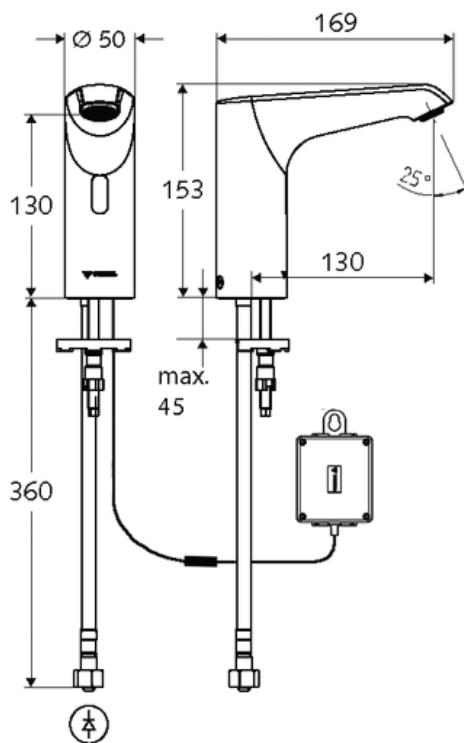

- (High pressure cold water) battery option, suitable for connection with SWS, capable of being parameterised by SSC
- Infrared sensor single hole tap
- Electronic module programmable
- Connection cable (length 220 mm) with plug protection class IP 65
- axial solenoid valve 6 V
- External battery compartment
- 4 x AA alkaline batteries
- Flexible connection hose Clean-Fix S G 3/8 int. thread x 400 mm with backflow preventer (BP, DIN EN 1717:EB) and pre-filter
- Flow regulator
- Wash basin mounting accessories
- Flow volume: max. 5 l/min independent of pressure
- Flow pressure: 1 to 5 bar
- Max. resting pressure 8 bar
- Water temperature max. 70°C (80°C permissible for 10 min./day)
- Adjustable hand programming
 - Sensor range: short, medium, long
 - Stagnation flush program (duration of flow 30s, 24 h after last use/ every 24 h)
 - Flow time of continuous flush for thermal disinfection (duration of flow 300 s / duration of flow 120 s)
 - Cleaning stop 60 s



Xeris E

Schell Xeris E Basin Tap E-K Infrared Premixed Water

Code:
S0129406

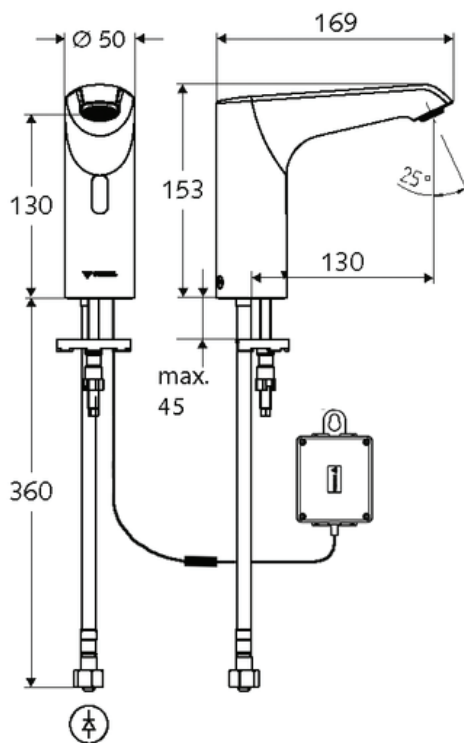

- Flow time adjustment via SWS/SSC
 - Max. flow time 1 360 s
 - Post-run time 0.6 - 60 s
 - Stagnation flush time 5 - 600 s
 - Stagnation flush intervals 1 - 240 h
 - Flow time for thermal disinfection 15 - 600 s
 - Duration of flow 15 - 600 s
 - Energy saving mode activated 1 - 254 h
 - Cleaning stop 60 - 360 s
- Material: housing out of brass, plastic water supply
- Test Mark: P-IX 29072/IO, WELL Public
- Surface: chrome
- Weight: 1.8 kg/pc.
- Packaging unit: 1

- RECOMMENDED ASSOCIATED ITEM:
 - SSC Bluetooth®-Module 00 916 00 99
 - Angle valve with regulating function COMFORT with filter 05 430 06 99

 DESIGNED AND MANUFACTURED IN GERMANY

